

# *Sunbeam*<sup>®</sup> *Allergysmart*<sup>™</sup>

**ALLERGEN DETECTOR AND AIR CLEANER**

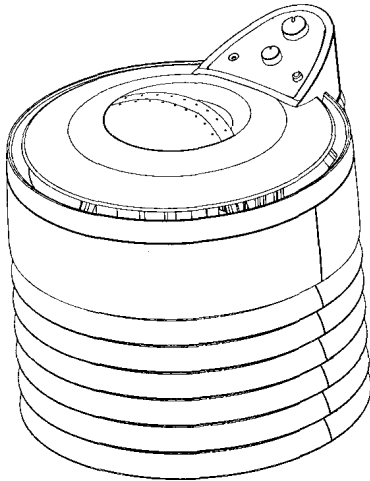

## **Models 2540/2541 USE AND CARE MANUAL**

**CAUTION:** These guidelines and safeguards help ensure that your new air cleaner operates effectively. Please read all instructions carefully before using your appliance.

**QUESTIONS:** If you have questions or comments please call us at  
1-800-597-5978

**THE FIRST AND ONLY AIR CLEANER THAT DETECTS AND MONITORS  
THE LEVEL OF ALLERGEN PARTICLES IN THE AIR**

## IMPORTANT SAFEGUARDS

When using electrical appliances, basic safety precautions should always be followed, including:

1. **READ ALL INSTRUCTIONS CAREFULLY.**
2. To reduce the risk of electrical shock, this equipment has a grounded type of plug that has a third (grounding) pin. This plug will only fit into a grounded type of power outlet. If the plug does not fit into the outlet, contact qualified personnel to install the proper outlet. Do not alter the plug in any way.
3. Keep the cord out of high traffic areas. To avoid fire hazard, never put the cord under rugs, near heat registers, radiators, stoves or heaters. Keep the cord away from heated surfaces.
4. Do not immerse in water or other liquids. Do not use while bathing.
5. Close supervision is necessary when any appliance is used near children or incapacitated persons.
6. Always unplug the air cleaner before moving it, cleaning or changing filters, or whenever the air cleaner is not in use.
7. Do not put foreign objects inside the air cleaner
8. Do not operate this appliance with a damaged cord or plug, or if the fan fails to rotate, or has been dropped or damaged in any manner. Return the appliance to manufacturer for examination or repair. (See warranty for information)
9. Use appliance only for intended household use as described in this manual.
10. Do not use outdoors.
11. Never block the air opening or place on a soft surface such as a bed or sofa where the opening may be blocked.
12. Laser light present. Do not attempt to service or disassemble the unit yourself.

SAVE THESE INSTRUCTIONS

## CONGRATULATIONS ON YOUR PURCHASE....

The Sunbeam® Allergysmart™ Air Cleaner is the first and only air cleaner made today that detects and monitors the level of allergen particles in the air. If you have any questions or comments, please feel free to call us at 1-800-597-5978. Our customer service representatives will be happy to assist you.

REVOLUTIONARY **ALLERYSMART™** TECHNOLOGY DETECTS AND MONITORS  
THE LEVEL OF AIRBORNE ALLERGENS...

## WHY ALLERYSMART™?

Many doctors agree that air cleaners help to reduce allergy and asthma-related symptoms by reducing allergen particles in the air. These allergens may include, among others, dust mites, pet dander, mold spores, and pollen from weeds, trees, or grasses. Only with the Allergysmart™ sensor do you get monitoring and feedback about the level of allergen particles in your air-and the confidence you need that your indoor air is improved.

## HOW MANY ALLERGENS ARE IN MY HOME?

The types of allergens and the level of allergens in your home vary widely depending on the environment (different parts of the country, seasons of the year, etc.) the age of your home, the activity level within your home, and the presence of pets.

Approximately 95% of all allergens range in size from 3 to 50 microns. The Allergysmart™ sensor measures level of these allergen sized particles in the room.



pollen



mold & spores



dirt, dust, fibers  
& dust mites



pet dander

Independent research in various rooms and homes conducted by the Stevens Institute of Technology shows that these levels of allergen sized particles vary from 10 to over 1,000 particles in the home. Allergen particle levels will be affected by room type and/or activity level in your home.

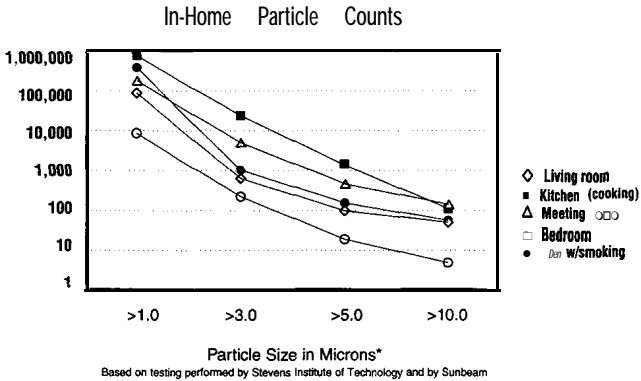

## REDUCING THE LEVEL OF ALLERGENS IN THE HOME

There are steps you can take to reduce the level of allergens in your home in addition to the use of an Allergysmart air cleaner. Following are some suggestions to help minimize your families exposure:

### Pollens

- Keep windows closed during pollen seasons
- Bathe and wash hair at night to prevent bringing allergens to bed
- Use a True HEPA air cleaner

### Pets

- Keep pets outdoors or out of your bedroom
- Wash hands immediately after handling
- Vacuum frequently

### Dust Mites

- Use allergy proof covers on mattresses and pillows
- Wash bed linens weekly in hot water
- Vacuum daily and dust frequently
- Replace carpeting with hardwood floors
- Use a dehumidifier-dust mites thrive in high humidity

## Mold Spores

- Use a dehumidifier
- No potted plants inside the home
- Remove visible mold growing in bathroom and/or kitchen

### HOW THE **ALLERGYSMART™** SENSOR ACTUALLY WORKS:

The **Allergysmart™** sensor was designed to detect and measure the level of allergen-sized particles (3-50 microns) in the air. While the sensor does not detect smaller sized particles such as dust or smoke, these particles will be captured by the HEPA filter. Here's how it works:

1. The fan in the sensor constantly samples the air.
2. A laser beam light in the sensor measures the level of allergen sized particles in the sampled air and sends a signal to the air cleaner.
3. When the level of particles exceeds the setting you choose (average, extra, super), the sensor automatically turns on the air cleaner for 30 minutes. After 30 minutes, the air cleaner turns off and the sensor resamples the air. If the level of particles exceeds the sensitivity setting you chose, the sensor turns on the air cleaner for another 30 minutes, and will continue to run and resample in 30 minute intervals until the allergen particle level has been reduced.
4. Lights on the control panel indicate the level of allergen particles.

#### AIR QUALITY

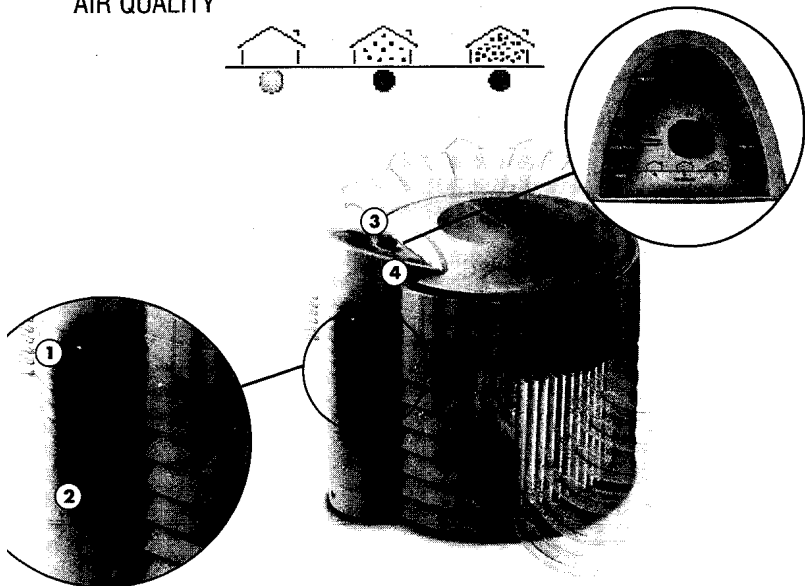

## ADJUSTING THE SENSITIVITY SETTING OF THE ALLERGYSMART™ SENSOR

You can adjust the operation of the air cleaner by changing the sensitivity setting of the sensor (average, extra, super). The higher the sensitivity setting, the fewer the particles counted before the air cleaner comes on. The chart below shows the particle counts that activate the air cleaner at the various settings\*.

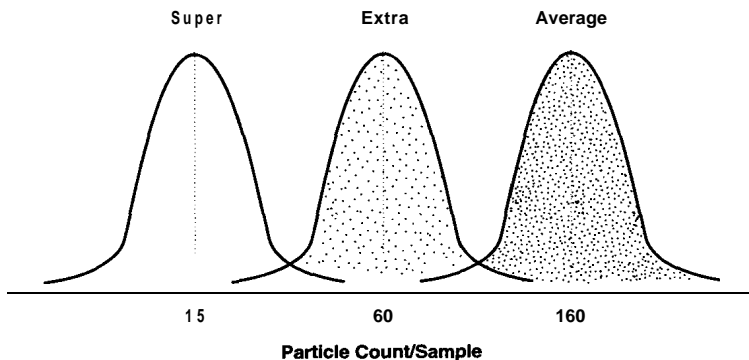

\*Particle counts indicated are mean averages. Slight variations exist from unit to unit. Sensitivity levels will vary among individuals based upon factors such as level and type of individual allergic reactions and personal concerns.

## OPERATING INSTRUCTIONS

### TO RUN YOUR AIR CLEANER AUTOMATICALLY USING THE ALLERGYSMART™ SENSOR...

Your air cleaner will run automatically, turning on and off, depending on the level of allergen-sized particles in the air sampled and the sensitivity setting you have selected. The automatic mode is activated by selecting a position on the sensitivity dial setting (average, extra, super) other than OFF/manual.

Once one of these sensitivity settings is selected, select your preferred fan speed (sleep, low, medium, or high).

The Allergysmart™ sensor is now activated. You will see a blinking green light, indicating that the sensor is testing.

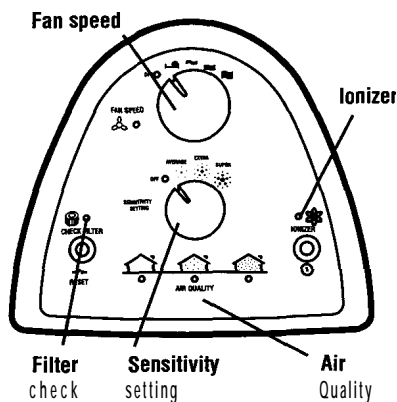

At the end of the testing interval, (up to 30 seconds) the display will indicate the level of airborne allergens particles measured. If the display indicates a moderate (yellow light) or high (red) level, the air cleaner will automatically turn on for 30 minutes. At the end of 30 minutes, the sensor will resample the air (blinking green light). If the level of allergen particles detected by the sensor is less than the sensitivity setting you selected, the air cleaner will remain off, and the sensor will continue to constantly sample the air (blinking green light) until it detects that the particle level has exceeded the sensitivity setting you chose.

### TO RUN YOUR AIR (LEANER MANUALLY...

1. Turn the sensitivity setting to the OFF/manual position.
2. Choose one of the four fan speeds (sleep, low, medium, high).  
The air cleaner will run continuously until you shut it off.

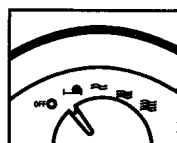

### TO USE THE IONIZER...

Push down the ionizer button. The indicator light will come on. The ionizer is now operating and will continue to operate whether the air cleaner is on or off.

## TIPS FOR OPERATING YOUR ALLERGYSMART™ AIR CLEANER

1. Place your air cleaner near the center of the room or in an area where the unit can operate without impediments to the airflow.
2. Turn your air cleaner so that the Allergysmart detector can freely sample air (do not put the detector in a corner or otherwise impede air flow to the detector).
3. Experiment with the location and sensitivity and fan speed settings on your unit. If you feel that your home's air continues to contain allergen particles after running the unit at a low fan speed (sleep, low or medium) or at a lower sensitivity setting (average or extra), try increasing the fan speed to medium or high and/or increasing the sensitivity setting to extra or super. You can also try repositioning the unit in your room. Remember that the higher the sensitivity setting, with super being the highest, the lower the particle count required to cause the unit to turn on. If you feel that the unit is running too often, reduce the sensitivity setting (i.e. change the sensitivity setting from super to extra or average).

If you feel that your home's air needs constant cleaning, for instance during high pollen count days, you should manually operate the unit to run constantly (see page 7 for instructions).

4. Manually turn your air cleaner on if you see, smell or otherwise notice smoke in the air. The Allergysmart sensor does not detect smoke particles in the air due to their small size; however, the Allergysmart air cleaner does reduce smoke particles in the air with a True HEPA filter which will remove particles as small as 3 microns from the filtered air.
5. The **Allergysmart™** detector does not sense differences in types of allergy particles. If you are allergic to a particular type of allergen (such as pollens) you may want to adjust the sensitivity setting on your air cleaner because of changes in your home's air.

**Caution: Individuals with acute respiratory problems should consult with their physician regarding use of an air cleaner as part of a treatment program.**

## OTHER FEATURES OF YOUR ALLERGYSMART™ AIR CLEANER

In addition to the **Allergysmart™** Allergen Monitor, this Sunbeam air cleaner is equipped with the following features:

### TRUE HEPA FILTER

Certified to capture 99.97% of all contaminants .3 microns or larger.

### CHARCOAL PRE-FILTER

Reduces odors and extends the HEPA filter life.

### FILTER CHECK REMINDER LIGHTS

Reminds you to check to see if your filter needs replacement.

### IONIZER

An added stage of filtration to further clean the room. The ionizer negatively charges small particles not captured by the HEPA filter as they leave the air cleaner. These tiny charged negative particles will combine with other larger positively charged particles that can then be filtered out of the air through the air cleaner.



## CLEANING CAPACITY

Your air cleaner has the capacity to clean the air in a 10' x 12' room every 5 (model 2541) or 8 (model 2540) minutes on the high fan speed setting. Your air cleaner has a total of four fan speed settings, including an extra quiet sleep setting. Adjust fan settings as needed. The sleep setting will be the quietest setting but will also be the lowest performing in terms of the capacity of air cleaned.

## FILTER MAINTENANCE/REPLACEMENT INSTRUCTIONS

### CHECKING THE FILTER

ALWAYS UNPLUG THE UNIT BEFORE CHECKING THE FILTER.

The check filter light indicates when it's time to check your HEPA or charcoal filter to see if it needs replacement. If the light is:

#### Blinking

Check the charcoal filter for possible replacement (usually 3 months after initial usage). Check the appearance of the filter to see if there is a visible amount of dust or lint on the filter. If so, you will need to replace the charcoal filter with replacement model #6620 for the model 2540 air cleaner, or #6622 for the model 2541 air cleaner. See instructions below for replacing the filter. After you have checked or replaced the filter, make sure to press the RESET button.



New



In use



In use



Time to change

#### Solid

Check the HEPA filter for possible replacement (usually a minimum of 1 year after the initial usage). If the filter appears brown in color, it is time to replace the filter. Use replacement filter model # 6619 for model 2540 air cleaner and #6621 for model 2541 air cleaner. See instructions below for replacing the filter. After you have checked or replaced the filter, make sure to press the RESET button.

## CHANGING THE FILTER

1. Always unplug the unit prior to replacing the filter.
2. To remove the filter, turn the unit upside down and unscrew the knob at the base of the air cleaner.
3. Remove the old filter and replace with a new filter.
4. Replace base of unit and screw knob back in place.
5. Both the HEPA and charcoal filters can be replaced at your local retailer or ordered by mail. (see enclosed form)

NEVER ATTEMPT TO SERVICE OR  
DISASSEMBLE THE UNIT YOURSELF  
(other than replacing the filter).

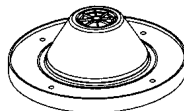
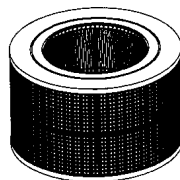
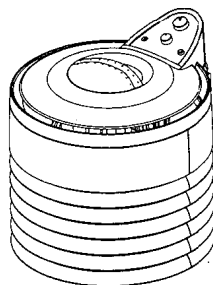

## CLEANING INSTRUCTIONS

1. Always unplug the unit before cleaning and when not in use.
2. Outside surfaces intake or vents can be cleaned with a soft cloth.
3. Do not submerge in water, or allow water to come in contact with the air cleaner.

## 2 YEAR LIMITED WARRANTY

Sunbeam Products, Inc. warrants to the original purchaser, for a period of two years from date of purchase, this product shall be free of mechanical and electrical defects in material and workmanship subject to the limitations and exclusions set forth below. This warranty does not cover normal wear of parts or damage resulting from any of the following: negligent use or misuse of the product, use on improper voltage or current, use contrary to the operating instructions or disassembly, repair or alteration by any person other than an authorized service center. Our obligation hereunder is limited to repair or replacement, at manufacturer's option, of this product during the warranty period, provided that the product(s) purchased along with the model number and original dated proof of purchase, are sent postage pre-paid directly to:

**Sunbeam Appliance Service Station  
117 Central Industrial Row  
Purvis, MS 39475**

Answers to questions regarding this warranty or your nearest U.S.A. authorized service location may be obtained by calling toll-free 1-800-597-5978 or by writing to Sunbeam-Consumer Affairs at P.O. Box 948389, Maitland, Florida 32794-8389.

DO NOT RETURN THIS PRODUCT TO THE PLACE OF PURCHASE; DOING SO MAY DELAY THE PROCESSING OF YOUR WARRANTY CLAIM.

### DISCLAIMER

Product repair or replacement as provided under this warranty is your exclusive remedy. SUNBEAM PRODUCTS, INC. SHALL NOT BE LIABLE FOR ANY INCIDENTAL OR CONSEQUENTIAL DAMAGES FOR BREACH OF ANY EXPRESS OR IMPLIED WARRANTY ON THIS PRODUCT OR ANY PART THEREOF. EXCEPT TO THE EXTENT PROHIBITED BY APPLICABLE LAW, SUNBEAM PRODUCTS, INC. DISCLAIMS ANY IMPLIED WARRANTY OR CONDITION OF MERCHANTABILITY OR FITNESS FOR A PARTICULAR PURPOSE OF THIS PRODUCT OR ANY PART THEREOF. Some states do not allow the exclusion or limitation of incidental or consequential damages, or allow limitations on how long an implied warranty lasts, so the above limitations or exclusions may not apply to you. This warranty gives you specific legal rights, and you may also have other rights, which vary from state to state.

**Allergysmart™** is a trademark of Sunbeam Corporation or its affiliated companies. Sunbeam@ is a registered trademark of Sunbeam Corporation or its affiliated companies. 01997 Sunbeam Corporation or its affiliated companies. All rights reserved. Distributed by Sunbeam Products, Inc., Delray Beach, Florida 33445.

This product may be covered by U.S. Patent Numbers 5,001,463 and 5,646,597, and additional U.S. and/or foreign patents.

# TO ORDER REPLACEMENT FILTERS BY MAIL

## Mail Order Form

In the U.S., to order the following parts by credit card, please call:  
 Sunbeam Products, Inc. at 1-800-597-5978, or mail a check with this mail-order form to: Sunbeam Products, Inc., Consumer Affairs Department PO Box 948389, Department PT., Maitland, FL 32794-8389

Model No.	Description	Quantity	Price Each	Total
6619	Small HEPA Filter (For Model 2540)		<del>\$59.99</del>	
6620	Small Charcoal pre-filter (For Model 2540)		\$ 9.99	
6621	Large HEPA Filter (For Model 2541)		<del>\$69.99</del>	
6622	Large Charcoal pre-filter (For Model 2541)		\$14.99	
			Shipping/Handling	<del>\$3.00</del>
			Total amount enclosed	

All taxes included in price.

Mail check or money order  
 (made payable to Sunbeam Products, Inc.) to:

Sunbeam Products, Inc.  
 Consumer Affairs Department  
 PO Box 948389  
 Maitland, FL 32794-8389

**DO NOT SEND CASH**

Please allow 4-6 weeks for delivery

\_\_\_\_\_  
 Name

\_\_\_\_\_  
 Address

\_\_\_\_\_  
 City State Zip